

***WATERSNAKE  
ELECTRIC MOTOR  
OWNERS MANUAL  
SWET SERIES TRANSOM MOTOR***

**Jarvis**   
**Marine**®

## **WATERSNAKE ELECTRIC MOTORS**

Congratulations and welcome to a world of silent motoring. You won't regret your purchase of a lightweight, Jarvis Marine Watersnake electric motor.

This powerful yet silent, the Watersnake electric motors are built to suit all angling conditions. High quality materials, superior design and precision engineering make these motors longwearing and reliable.

### **ATTACHING THE MOTOR TO YOUR BOAT**

Attach the motor to the stern of the boat and tighten both mounting bolts securely while taking care not to over-tighten. **(A)**

To adjust the angle of the motor after attachment, hold the motor head with one hand and depress the positioning pin at the top of the mounting bracket with your other hand. Press and hold the positioning pin until the desired angle has been reached, next release the pin and ensure the mechanism locks securely. **(B)**

**(A)**

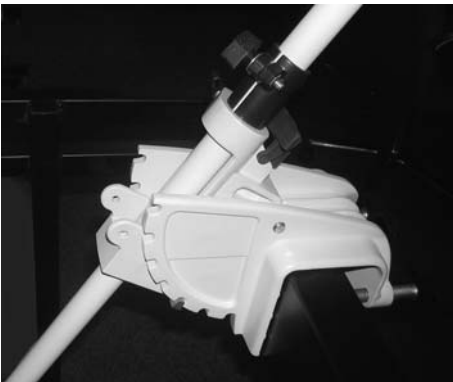

**(B)**



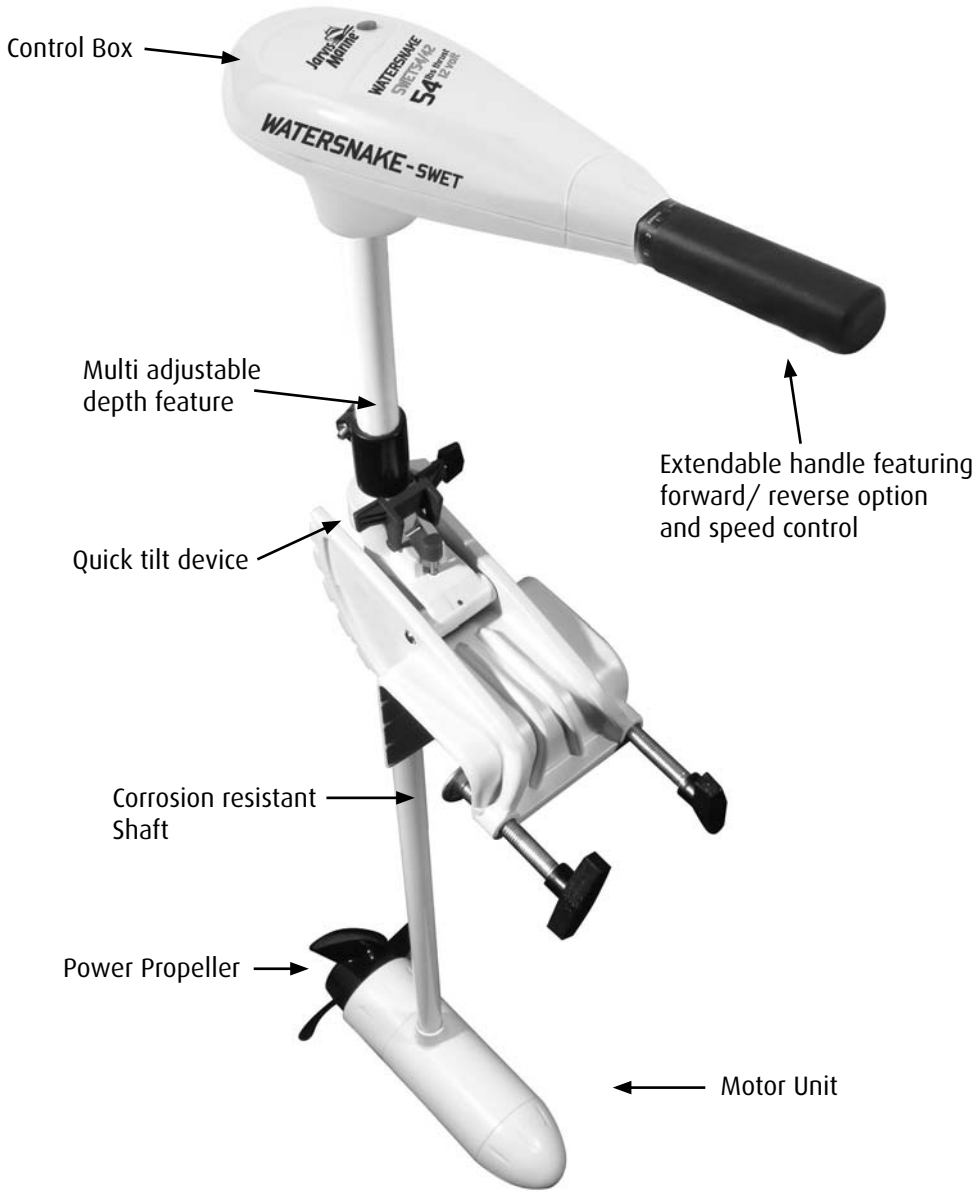

## **DEPTH ADJUSTMENT**

Hold the motor shaft with one hand, loosen the depth adjustment screw and set the motor to the desired depth, then retighten the adjusting screw securely. **(C1)**

## **STEERING**

To adjust steering counter-force, simply loosen or tighten the counterforce bolt. The ideal setting is one where the counterforce bolt is just tight enough so that the boat will steer in the direction you are aiming without need for continual correction. **(C2)**

## **SPEED CONTROL**

The tiller control is telescopic and can be extended to a length of 16cm. The speed control, featuring five forward and two reverse speeds, is integrated into the handle. Turn the handle clockwise to move forward and anti-clockwise to go backwards. When you don't want to move, set the handle into neutral. **(D&E)**

**(C)**

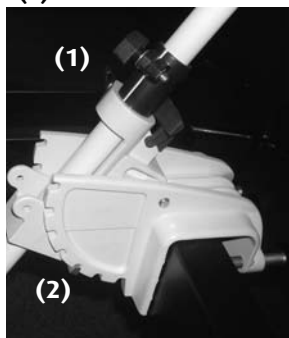

**(D)**

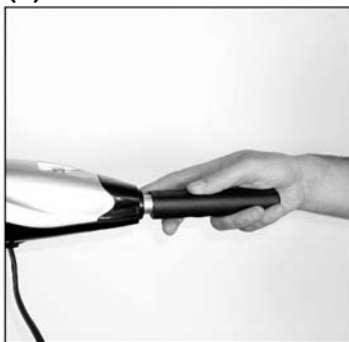

**(E)**

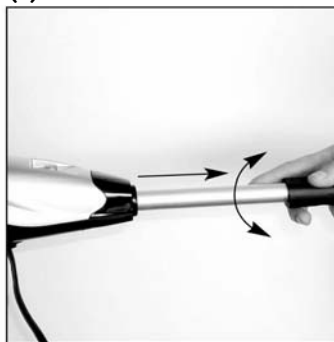

## **CHANGING THE PROPELLER**

**Before doing anything with the propeller, ensure the cables to the battery are disconnected.** Detaching the propeller it is a simple matter of unscrewing and removing the locknut using the special tool supplied. When doing this, take hold of the propeller to stop it turning. Under no circumstances should you attempt to loosen the locknut with a hammer or similar tool as this may damage the locknut or shaft – or both. **(F)**

Once the locknut is removed, you will be able to slide the propeller off. When putting the propeller back on, verify there is a proper fit of the groove and shear pin otherwise the propeller will not be locked in place. **(G)**

After using the motor always check and clear any weed or fishing line that may have become tangled around the propeller. Next, give the motor a wipe down with warm water to remove any salt or sand particles and then spray it with fresh water.

(F)



(G)



### ***ELECTRICAL CONNECTIONS***

Before connecting the motor's cables to the battery terminals, ensure all switches are in the OFF position and stand clear of the propeller.

Connect the red cable to the positive (+) terminal and the black cable to the negative (-) terminal, making sure the terminals are clean before doing so. A clean connection will minimise power wastage and give you maximum power from the battery.

The battery should be kept in a well-ventilated location. We recommend using a special deep cycle marine battery for optimum performance.

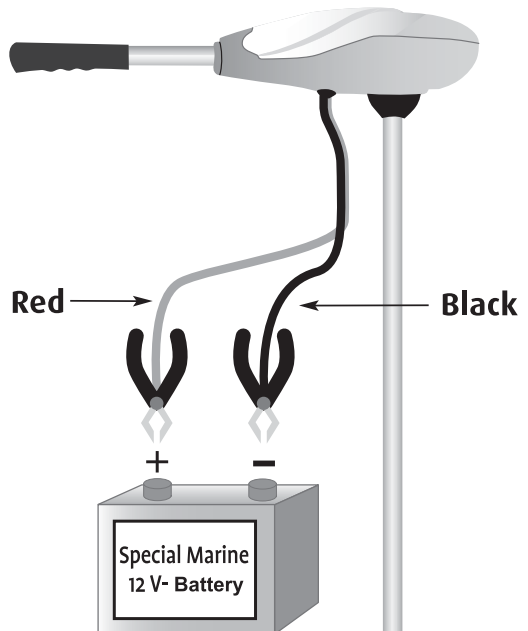

## ELECTRICAL CONNECTIONS CONTINUED

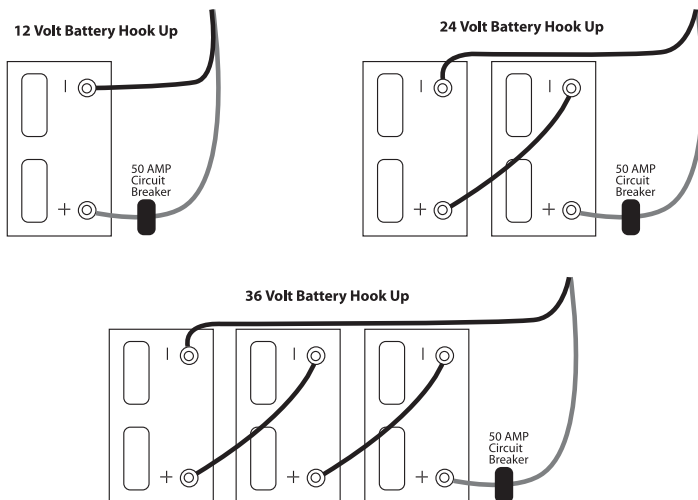

MODEL	MAX THRUST	CONTROL	SPEEDS	VOLTAGE	SHAFT MATERIAL	SHAFT LENGTH
SWET44	44lbs	By Hand	For5/Rev2	12V	Composite	36" / 91cm
SWET54	54lbs	By Hand	For5/Rev2	12V	Composite	42" / 105cm
SWET80	80lbs	By Hand	For5/Rev2	24V	Composite	48" / 121cm
SWET80	80lbs	By Hand	For5/Rev2	24V	Composite	54" / 137cm
SWET105	105lbs	By Hand	For5/Rev2	36V	Composite	54" / 137cm

## TROUBLESHOOTING

### PROBLEM

### POSSIBLE CAUSE/SOLUTION

Speed loss

- 1: Check for line or weed on propeller.
- 2: Check battery status.
- 3: Check terminals on battery.

Motor noise/ shake

- 1: Check propeller for line or weed.

- 2: Check to see propeller is secure and not damaged.
- 3: Check shaft to ensure it is not bent. Detach propeller and run motor visually to ensure shaft is not shaking. If shaft is damaged contact your retailer.

Loss of speed setting

- 1: Check all wiring connections.
- 2: Speed coil in motor may be burned, contact your retailer.

Tight steering

- 1: Loosen counterforce screw, apply lubricant and readjust.

**For problems not listed contact your retailer**

## ***MAINTENANCE***

At the end of the day, wipe the motor down with a cloth soaked in warm water and then rinse unit with light spray from hose. Always check the propeller is clear of line or weed, regularly check all nuts, bolts and screws and lubricate all moving parts with an aerosol lubricant. Clean terminal connections regularly and check for frayed wires or loose connections.

## ***STORAGE***

When storing the motor, lubricate all moving parts and screws and store in a well-ventilated, dry area. Do not leave the motor outside in winter for long periods, as this will damage the permanent magnet in the unit.

## ***JARVIS WALKER – 12 MONTH WARRANTY PROVISIONS***

### **1. Product safety**

Provision of the goods by Jarvis Walker in no way reduces the purchaser's obligation to ensure that their use of the goods and the relevant operating environment is safe and in accordance with Jarvis Walker's directions relating to care, maintenance and storage of the goods.

### **2. Product warranty**

All goods manufactured by Jarvis Walker that have been subjected to normal and proper use are warranted to be free from material defects in material and workmanship for a period of one year from the date of purchase. Jarvis Walker will use its reasonable endeavours to rectify at its cost any defect in the goods as provided in clause 2(a) notified to it during the warranty period.

The purchaser's sole remedy for a breach of clause 2(a) is the repair, replacement or resupply of the goods in accordance with clause 3.4.

Jarvis Walker will not be liable to rectify any defect in the goods if:

the goods have been altered or modified without Jarvis Walker's authorisation;

the defect is the result of or related to a failure of the purchaser to comply with any of its obligations under these terms; or the defect is the result of or related to the use of the goods other than in accordance with this documentation or Jarvis Walker's reasonable recommendations or directions.

**3. Limitations on Liability**

Limited and excluded liability

Unless this warranty provides otherwise, the maximum aggregate liability of Jarvis Walker for all proven losses, damages and claims arising out of this warranty, including liability for breach, in negligence or in tort or for any other common law or statutory action, is limited to the sum of the amount paid by the purchaser to Jarvis Walker. Notwithstanding any other provisions, Jarvis Walker will not be liable to the purchaser or to any other person for: any losses or damages of any kind caused by or resulting from any wrongful, wilful or negligent act or omission of Jarvis Walker or any of its officers, employees, agents or contractors; or any indirect, incidental, special or consequential damages, including loss of profits or anticipated profits, even if notified of the possibility of that potential loss or damage.

Exclusion of implied warranties

Any representation, warranty, condition or undertaking that would be implied in this warranty by legislation, common law, equity, trade, custom or usage is excluded to the maximum extent permitted by law.

Non-excludable rights implied by statute

Nothing in this warranty excludes, restricts or modifies any condition, warranty, right or remedy conferred on the purchaser by the Trade Practices Act 1974 (Cth) or any other applicable law and which cannot be excluded, restricted or modified by agreement.

Liability for breach of non-excludable rights

To the fullest extent permitted by law, the liability of Jarvis Walker for a breach of a non-excludable condition or warranty referred to in clause 3.3 and as otherwise provided for in these terms are limited, at Jarvis Walker's option, to the replacement of the goods or the supply of equivalent goods; the repair of the goods; the payment of the cost of replacing the goods or of acquiring equivalent goods; or the payment of the cost of having the goods repaired.

**4. Warranty service**

A copy of the proof of purchase or registration verification is required to obtain warranty service.

Please contact Anglers Central Service centre for servicing and Spare parts.

Anglers' Central Service Centre Pty Ltd, Australia's largest tackle repair centre and the authorised service and repair centre for all Penn, Rovex and Jarvis Walker and Jarvis Marine products throughout Australia.

email: spareparts@anglerscentral.com.au

Ph: 08 8244 8790 Fax: 1300 763 331

Delivery address: 2,7 Circuit Drive, Hendon SA 5014

***When applying for a warranty service please supply proof of purchase and a brief explanation of the fault.***

***Upon purchase please fill out the registration form below and send to Anglers Cental Service Centre: 2,7 circuit drive, Hendon SA 5014.***



**Important**

To Make the Warranty effective please complete this registration card correctly and return to us with a copy of your receipt within thirty (30) days after the date of purchase.

If you do not wish Jarvis walker to send you information on our products and services please tick here.

Name and Model .....

Place of Purchase ..... Date of purchase .....

Serial Number .....

Purchaser's Name .....

Address .....

.....

Signature .....

**PLEASE ATTACH A COPY  
OF PROOF OF PURCHASE  
HERE.**

**(RECEIPT)**

**YOU WILL REQUIRE IT TO MAKE A CLAIM.**